

N° OFF MOULD  
IN BAFFLE HTR 2.0

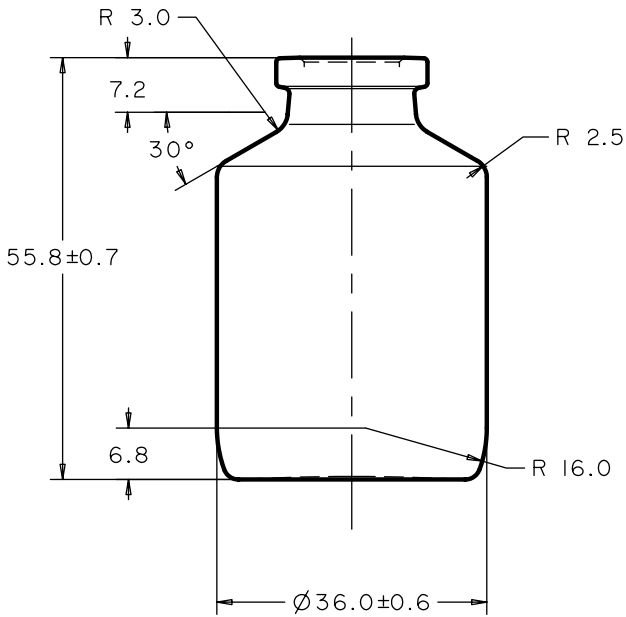

0	12-04-10	J.C.				20561	02
REP	DATE	NOTE	MODIFICATIONS			MOULD NO	INDEX
NECK FINISH ISO 20 8362-4			APPROX. WEIGHT : 27			MOULD	
Ø OPENING: 12.4 MINI SUR 7.5 MM 12.8 MAXI DN 1 MM DEPTH			BRIMFUL CAPACITY : 35			20561	
Ø 1 DIMENSION MIN : 11.5			GRAMMES cc ± 1.5 cc				

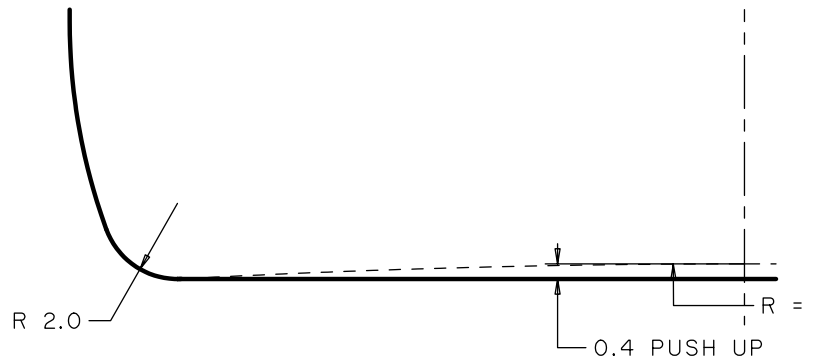
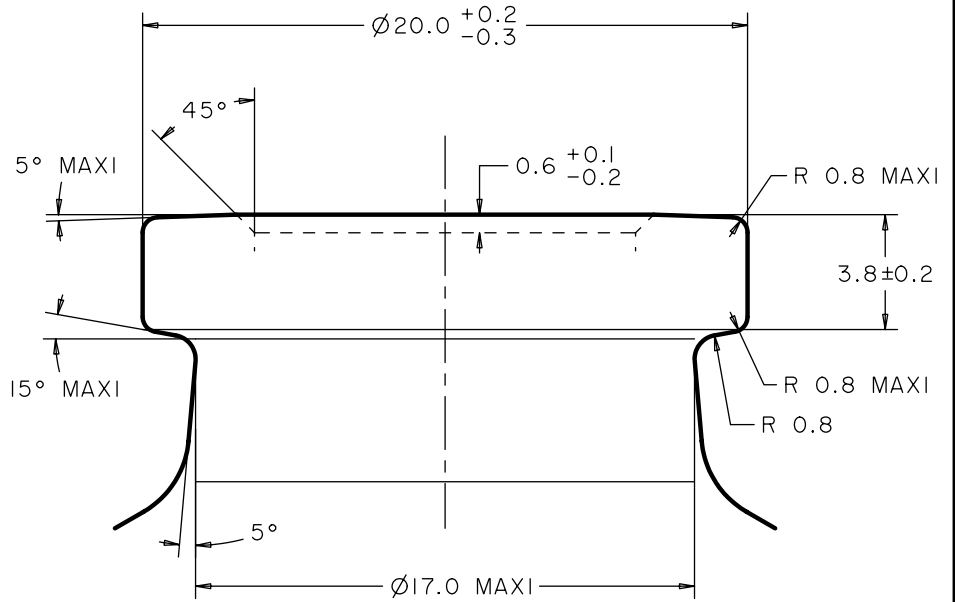
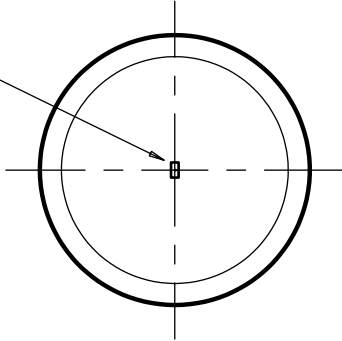

THIS DRAWING IS THE PROPERTY OF SGD AND CANNOT BE COPIED OR COMMUNICATED WITHOUT AUTORIZATION

**EASYLYO 30 ML**

MACHINE : 400

DATE : 12-04-10

PF  
78028

0	.
.	.
.	.