

NECK FINISH DETAIL
SCALE 5/1

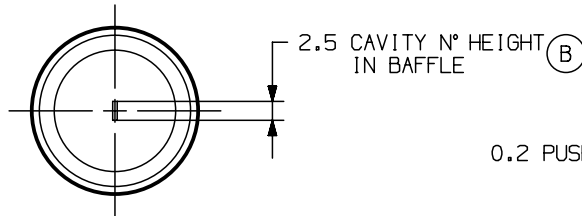

0.2 PUSH-UP

Detail A
Echelle: 5:1

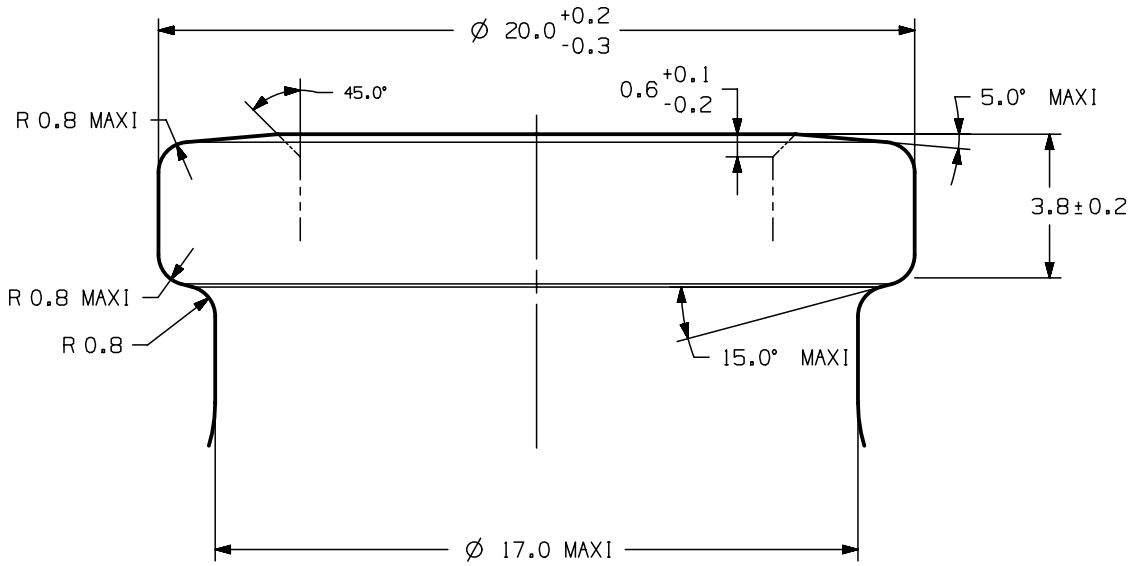
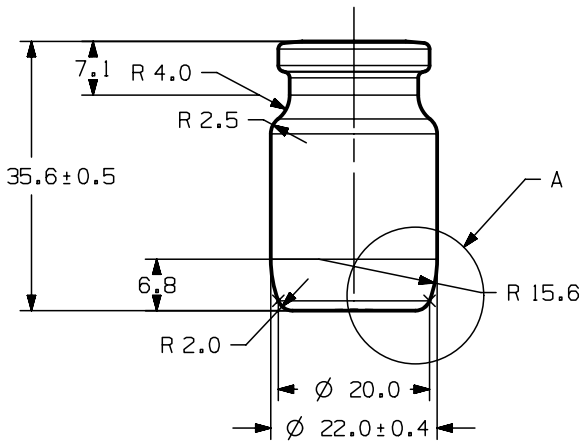

D						
C						
B	10-10-18	C.P.	WORDING MODIFICATION "CAVITY" REPLACE "MOLD"	03360	09	
O	07-09-18	T.C.		03360	09	
REP	DATE	NOTE	MODIFICATIONS	MOULD N°	INDEX	
NECK FINISH: ISO 20 8362-4			WEIGHT: 11.5 GRAMMES	MOULE		
Ø OPENING: 12.6±0.2 ON 1 MM DEPTH 12.4 MINI ON 7.5 MM DEPTH			BRIMFUL CAPACITY: 7.0 cc ± 0.5 cc	03360		
Ø I DIMENSION MIN: 11.5						



EASY LYO 5 ML

MACHINE

DATE 25-07-2018

E.D.
78207

B