

COTE DEPART FILET  
UN CRAN DECOR DIA 5  
SUR R 7.5

GRANITAGE

J-M

UN CRAN DECOR DIA 5  
COTE OPPOSE AU DEPART FILET  
SUR R 5

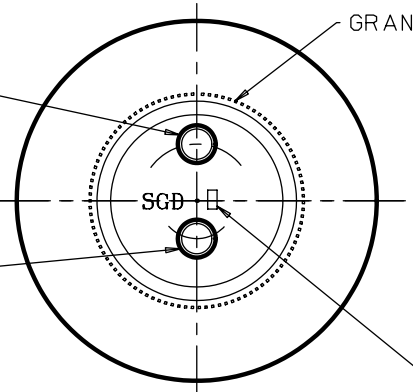

N° MOULE HTR 2.5  
EN CREUX

ZONE DECORABLE N° 101225, le 17/03/86

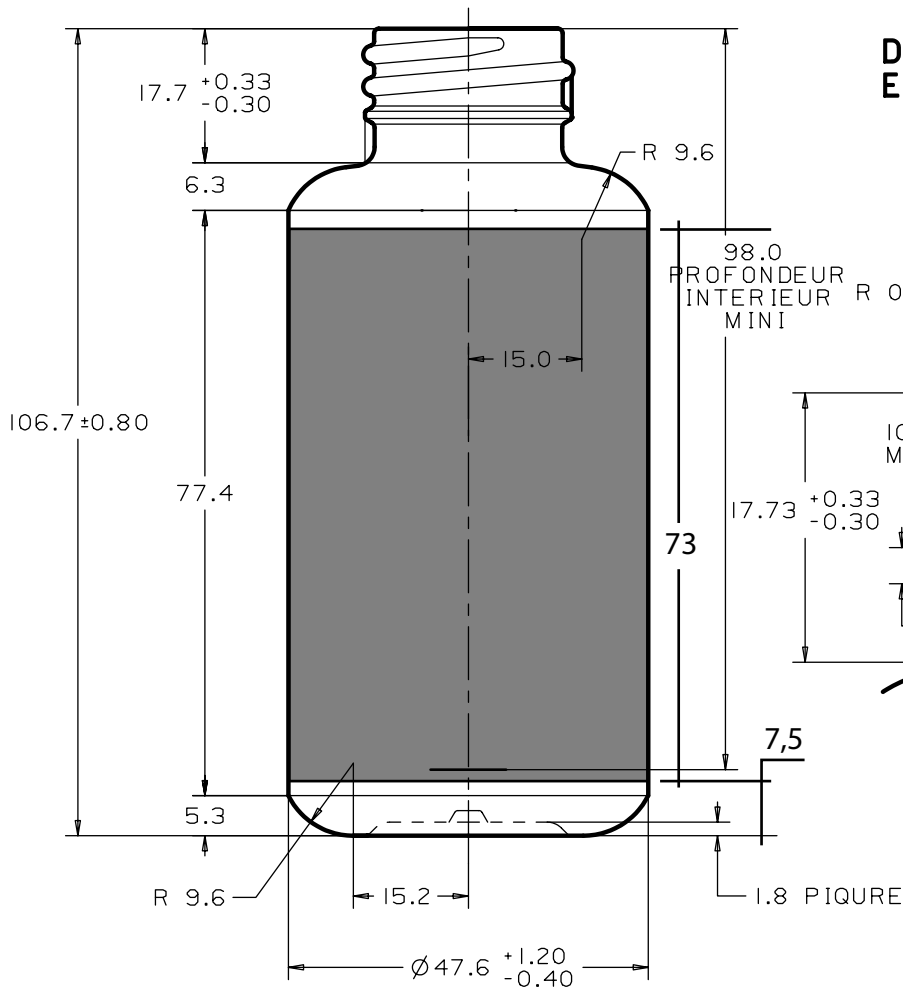

DETAIL BAGUE  
ECHELLE: 2

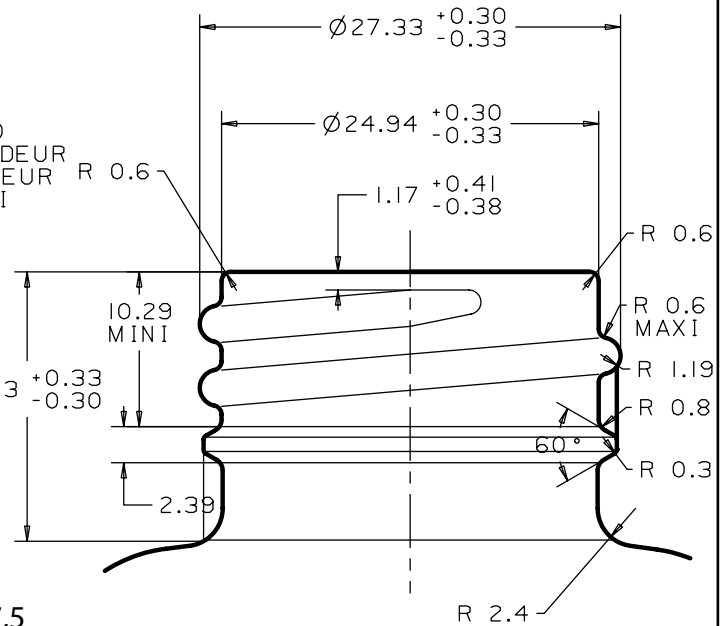

PAS: 4.23  
1 TOUR 1/4 DE FILET

G	01-10-02	J.C	AJOUT DETAIL BAGUE	60053	03
F	12.06.02	J.C.	AJOUT PROF. INT. MINI	60053	03
E	02-04-99	J.C	AJOUTE UN CRAN DECOR ET MODIF GRAVURE	60053	03
D	10-12-90	J.C	MODIF CARACTERISTIQUES	60053	03
C	12-06-90	J-C	MODIFICATION TOLERANCE OUVERTURE	60053	03
B	13-12-88	J-C	APPORT POSITION CRAN DECOR PAR RAPPORT AU DEPART FILET	60053	01
REP	DATE	NOTE	MODIFICATIONS	N MOULE	INDICE

BAGUE : GCM I.410.28.405	POIDS: 128	GRAMMES ENVIRON
Ø OUVERTURE: 18.8 <sup>+0.3</sup> / <sub>-0.2</sub> SUR 1 MM PROFONDEUR	CONTENANCE RB: 109	ML ± 3 ML
Ø MINI INTERIEUR COL: 15.59		

MOULE 60053						
MACHINE 201						
DATE 02.12.85						
PF 31130						
<table border="1"> <tr> <td>B</td> <td>C</td> </tr> <tr> <td>D</td> <td>E</td> </tr> <tr> <td>F</td> <td>G</td> </tr> </table>	B	C	D	E	F	G
B	C					
D	E					
F	G					



SAINT-GOBAIN DESJONQUERES

LAIT TANGO 100 ML