

CE PLAN ANNULE ET REMPLACE LE PLAN DE FABRICATION N : 31925 INDICE : 02 V:57.4 CC U:PLAN

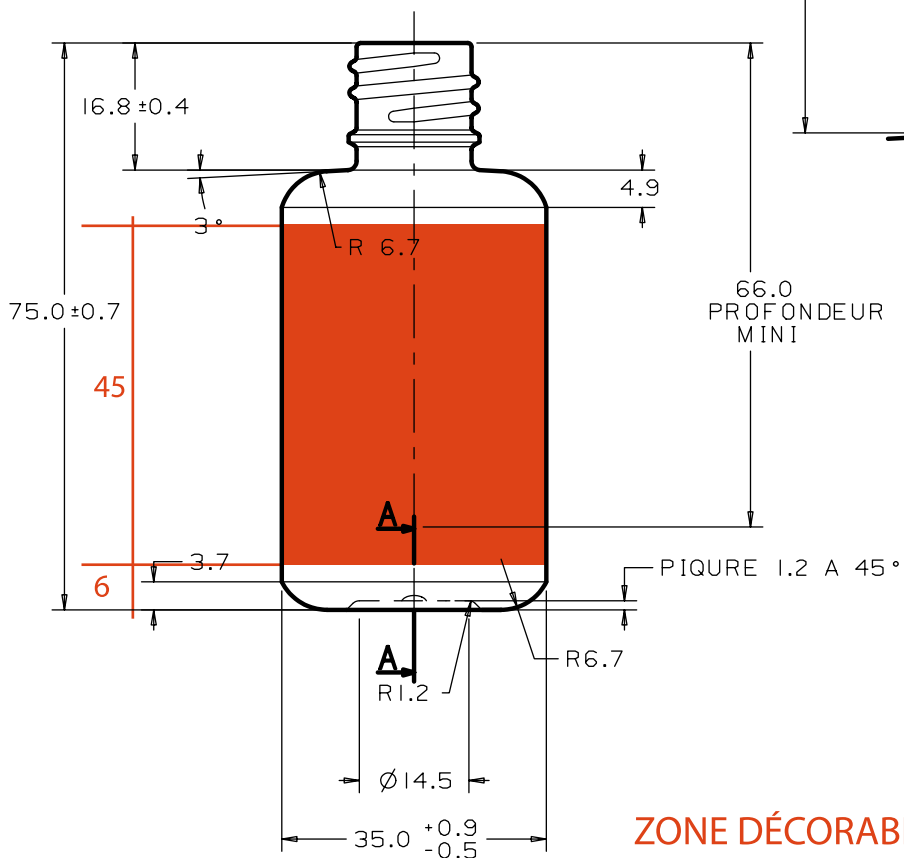

**COTE DEPART FILET**

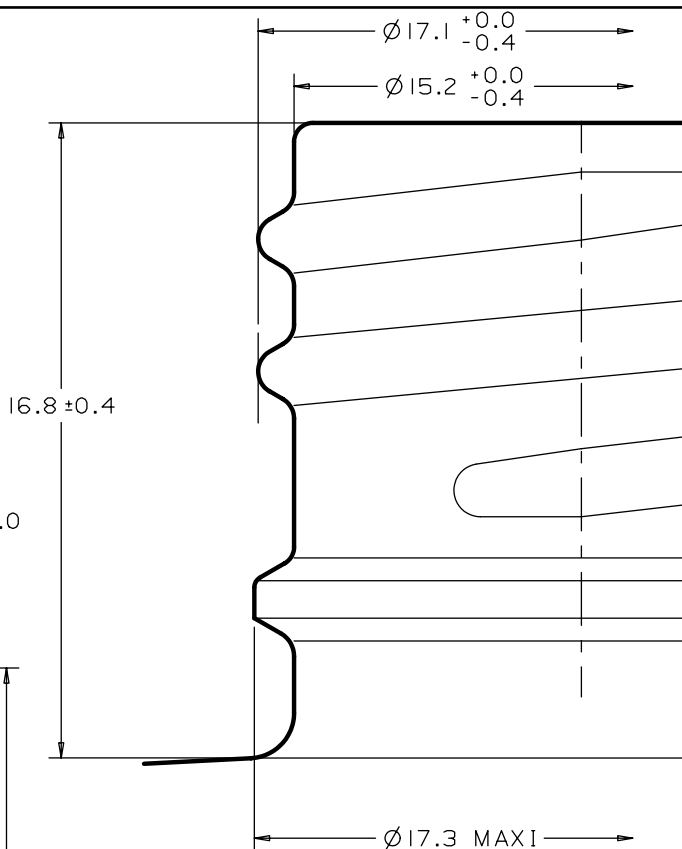
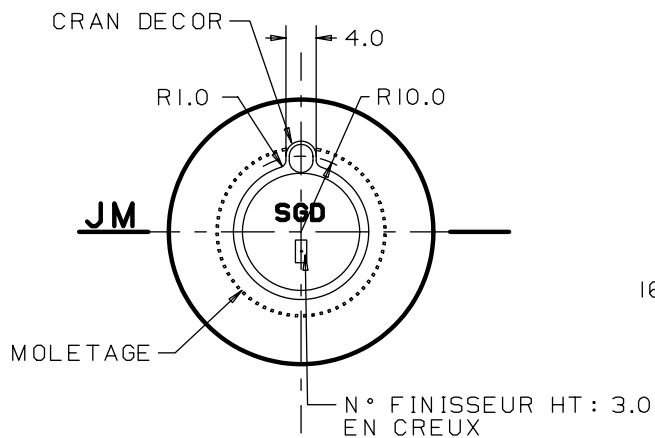
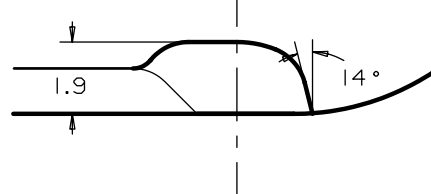

**DETAIL CRAN DECOR  
COUPE A-A  
ECH.: 5**



**ZONE DÉCORABLE CYLINDRIQUE N° 101227**

F	17-03-94	J.C	MODIF. CONTENANCE/PV, 35 ML & 55 GRS ETAIENT 34.2 & 57	60051	06
E	15.01.93	J.C	ETAIT MACHINES 207 - 301	60051	03
D	06.11.91	J.C	REGULARISATION HT GRAVURE EN CREUX	60051	03
C	12.12.88	J.C	APPORT POSITION CRAN DECOR PAR RAPPORT AU DEPART FILET	60051	03
B	17-08-87	J.C	COMPLEMENT MODIF	60051	03
D	18-06-87	J-C	.	60051	96
REP	DATE	NOTE	MODIFICATIONS	N MOULE	INDICE
BAGUE :EUROPA N° 5 H 35-050-088			POIDS: 55	GRAMMES ENVIRON	
Ø OUVERTURE: 9.8 ±.2 SUR 1 MM PROFONDEUR			CONTENANCE RB: 35	ML ± .2 ML	
Ø MINI INTERIEUR COL: 7					
 <b>SAINT-GOBAIN DESJONQUERES</b>			MACHINE 201-301		
			DATE 12-05-87		
 <b>TANGO DE 30 ML</b>			P.F	F.	
			32762		

CE PLAN EST NOTRE PROPRIETE ET NE PEUT ETRE REPRODUIT OU COMMUNIQUE A DES TIERS SANS NOTRE CONSENTEMENT

84.03.015 DD SUITE A PLAN N: 31925 /0 REF 60051 MOTIF BAGUE